

Submersible Motor Aerators 1800 Series

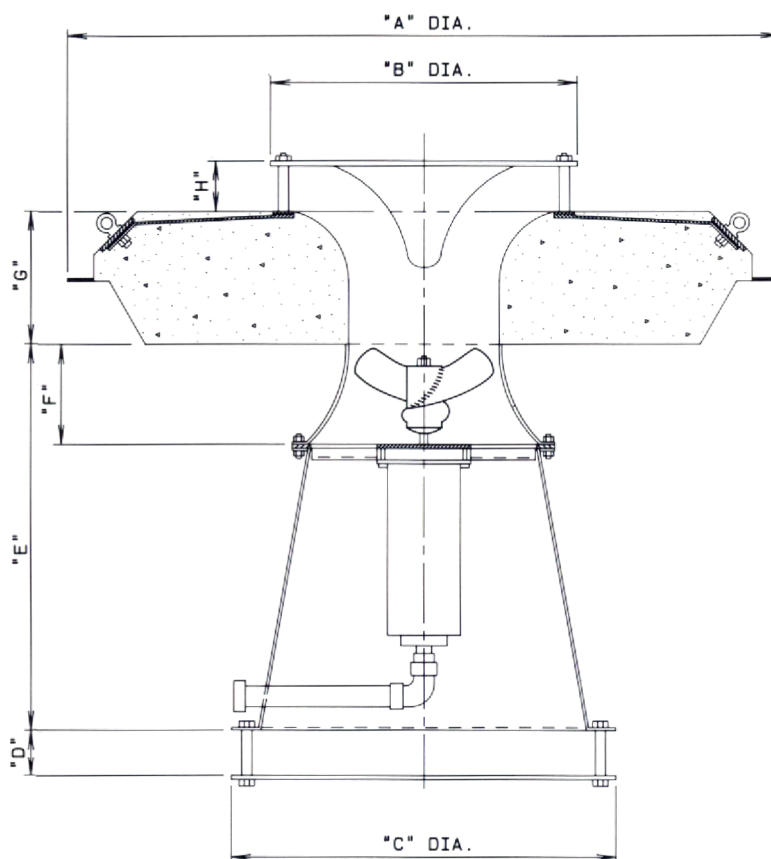

SKELLERUP
CONTAINMENT SYSTEMS

A Division of Viking Group Limited



1800 RPM Submersible Motor Aerator

Aerator Size	HP	'A'	'B'	'C'	'D'	'E'	'F'	'G'	'H'
FAS1801	1	152.4	60.9	86.3	15.2	60.9	20.3	31.7	7.6
FAS1802	2	152.4	60.9	86.3	15.2	60.9	20.3	31.7	7.6
FAS1803	3	152.4	60.9	86.3	15.2	60.9	20.3	31.7	7.6
FAS1805	5	152.4	60.9	86.3	15.2	60.9	20.3	31.7	10.6
FAS1807	7.5	152.4	60.9	86.3	15.2	55.8	15.2	35.6	10.6
FAS1810	10	182.8	60.9	86.3	15.2	55.8	15.2	35.6	12.7
FAS1815	15	182.8	60.9	86.3	15.2	55.8	15.2	35.6	12.7

When reliability matters