

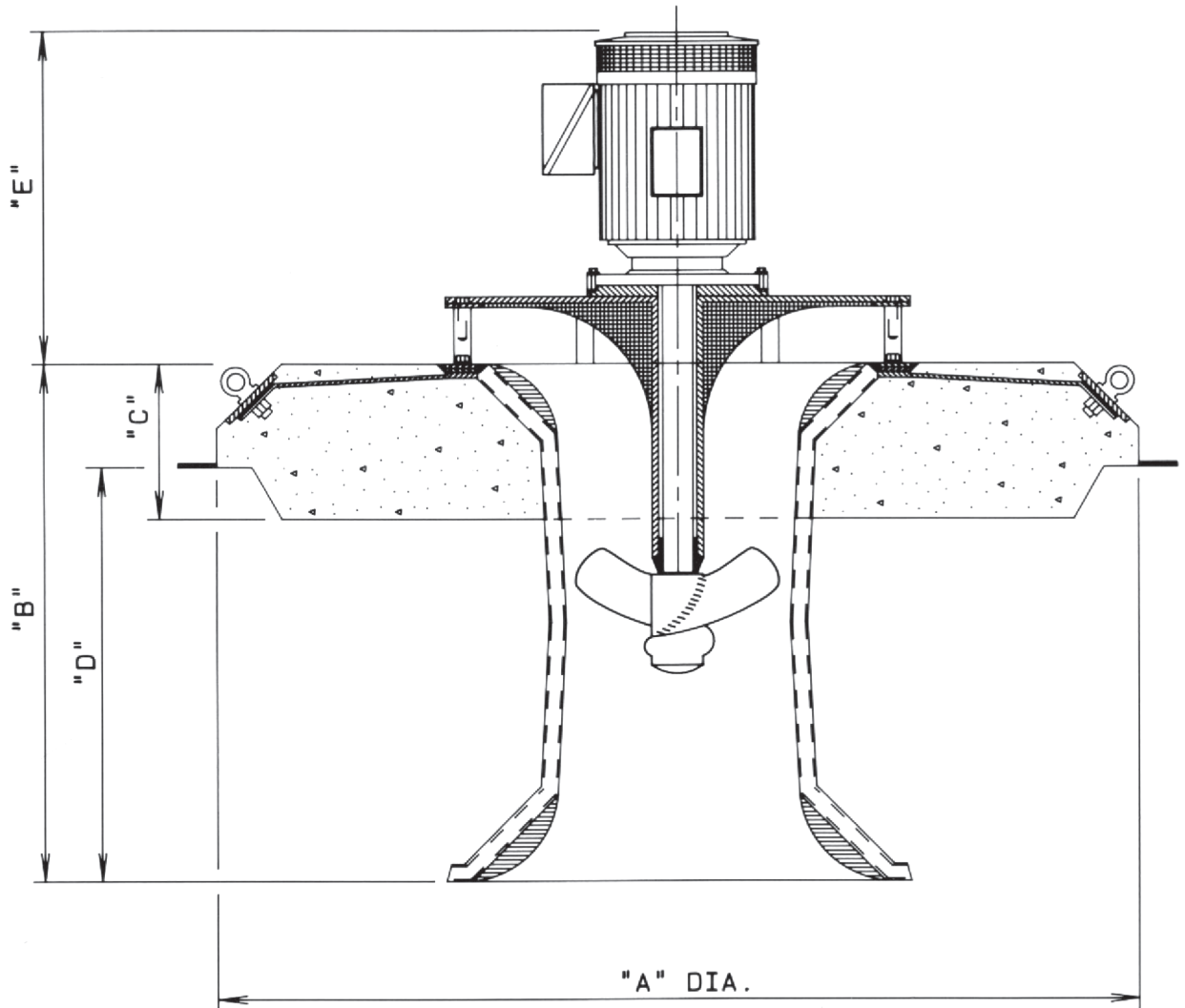

SKELLERUP

CONTAINMENT SYSTEMS

A Division of Viking Group Limited



1200 RPM Dimensions

Aerator Size	HP	'A'	'B'	'C'	'D'	'E'
FA1205	5	182.9	91.4	33.2	76.2	68.5
FA1207	7.5	182.9	91.4	33.2	76.2	68.5
FA1210	10	182.9	91.4	33.2	76.2	68.5
FA1215	15	182.9	124.4	38.1	101.6	78.7
FA1220	20	223.5	124.4	45.7	101.6	88.9
FA1225	25	223.5	124.4	53.3	101.6	93.9
FA1230	30	223.5	124.4	53.3	101.6	93.9
FA1240	40	243.8	137.1	53.3	106.6	96.5
FA1250	50	243.8	137.1	48.2	109.2	99.0

When reliability matters